

Quick Installation Guide

For product or function details, please go to www.tendacn.com.

Wireless N300 Home Router

Model: F6

Package contents

- Wireless router * 1
- Power adapter * 1
- Ethernet cable * 1
- Quick installation guide * 1

If any item is incorrect, missing, or damaged, please keep the original package and contact the local reseller or distributor immediately.

1 Connecting the router

- 1 Power off your modem, and remove its battery (if any).
- 2 Connect the WAN port of the router to a LAN port of your modem or to an Ethernet jack.
- 3 Power on your modem, and reinstall its battery.
- 4 Use the included power adapter to connect the router to a power source. The LED indicator lights solid on.
- 5 Connect your devices to the router.

Wireless devices: Connect wireless devices to the WiFi network of the router using the default WiFi name specified on the product label. By default, there is no WiFi password.

Wired devices: Connect wired devices to LAN1, LAN2 or LAN3 port of the router.

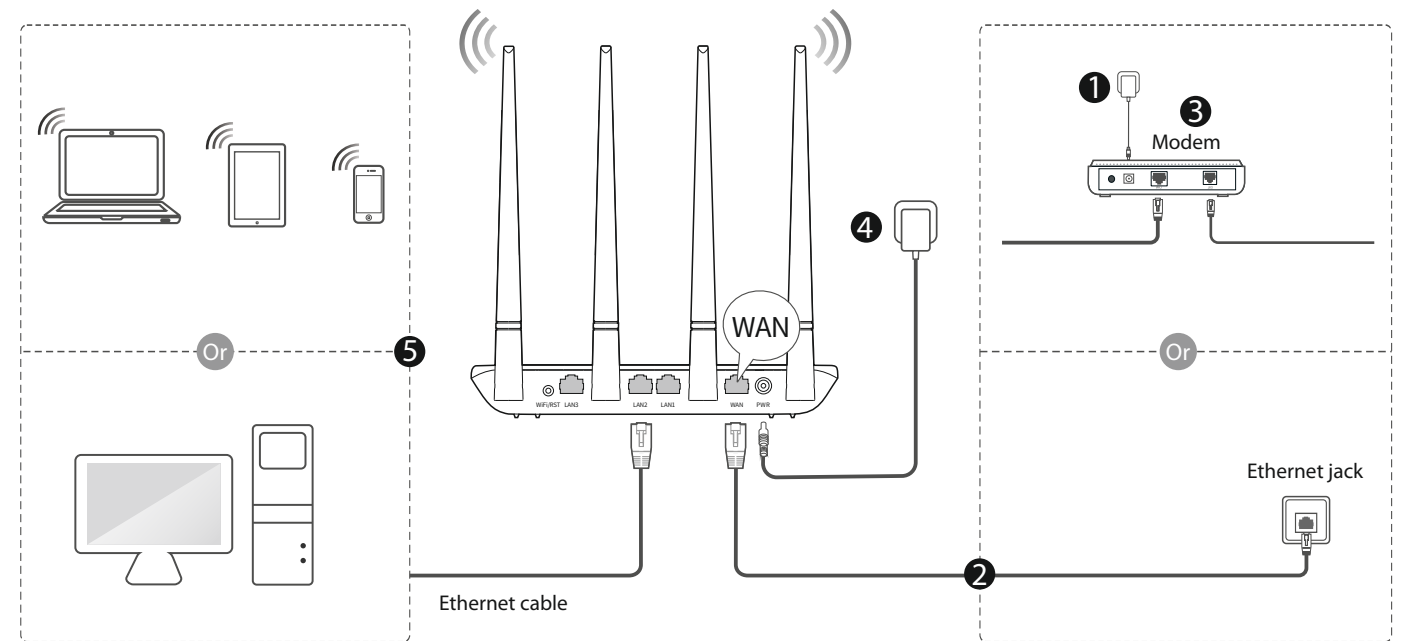

2 Setting up the router

1. Start a web browser on a computer connected to the router, enter **192.168.0.1** or **tendawifi.com** into the address bar, and press **Enter**.

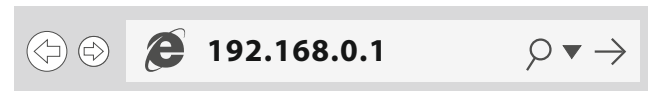

Tips
If you cannot log in to the web UI of the router, refer to **Q1** in **FAQ**.

2. The router detects your internet connection type automatically, which is PPPoE in this example. Enter the user name and password provided by your internet service provider (ISP), set up a WiFi name and WiFi password, and click **OK**.

Tenda
You can access the internet after completing settings on this page.

As detected, your connection type is: PPPoE

Internet
Connection Type PPPoE Dynamic IP Address Static IP Address
This type is applicable if you have a user name and password for setting up a broadband dial-up connection. You can import them from your original router.

User Name

Password

Wireless
WiFi Name

WiFi Password

OK

3. **Done.**

Connect your wireless devices to the WiFi network of the router again using the WiFi name and password you set. Your wired devices connected to the router can access the internet directly now.

Tenda
You can access the internet after completing settings on this page.

Saved!
You will be redirected to user interface after 3 seconds.

OK

LED indicators/Ports and Buttons

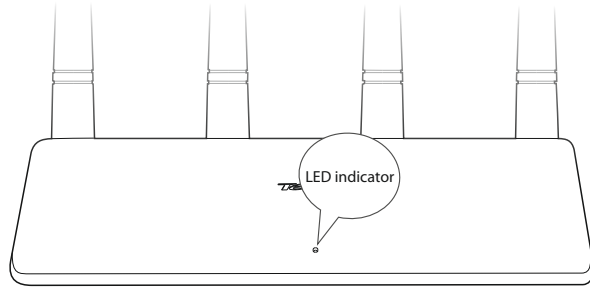

LED indicator	Status	Description
LED indicator	Solid on	The router is starting or connected to the internet successfully.
	Slow blinking	The router fails to connect to the internet.
	Fast blinking for 3 seconds	A wired device is connected or disconnected to the router.

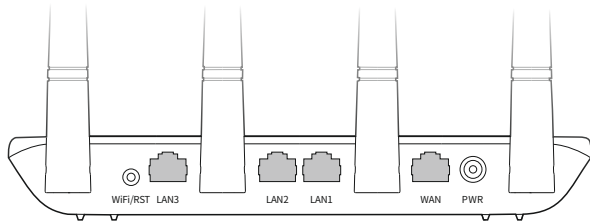

Button/Port	Description
PWR	Used to connect to the included power adapter.
WAN	Used to connect this router to the internet.
LAN1 LAN2 LAN3	Used to connect to wired devices such as computers or switches.
WiFi/RST	WiFi on/off button and reset button. - Hold the button down for 1~3 seconds to turn on or off the WiFi network of the router. - Hold the button down for about 8 seconds, then release when the LED indicator blinks fast. The router is reset successfully.



CE Mark Warning

This is a Class B product. In a domestic environment, this product may cause radio interference, in which case the user may be required to take adequate measures.

This equipment should be installed and operated with a minimum distance 20cm between the device and your body.

The mains plug is used as disconnect device, the disconnect device shall remain readily operable.

NOTE: (1) The manufacturer is not responsible for any radio or TV interference caused by unauthorized modifications to this equipment. (2) To avoid unnecessary radiation interference, it is recommended to use a shielded RJ45 cable.

WARNING: The mains plug is used as disconnect device; the disconnect device shall remain readily operable.

Declaration of Conformity

Hereby, SHENZHEN TENDA TECHNOLOGY CO., LTD. declares that the radio equipment type F6 is in compliance with Directive 2014/53/EU.

The full text of the EU declaration of conformity is available at the following internet address: <http://www.tendacn.com/en/service/download-cata-101.html>

Operating Frequency: EU/2412-2472MHz (CH1-CH13)

EIRP Power (Max.): 19 dBm

Software Version: V03.03.01.20_multi



RECYCLING

This product bears the selective sorting symbol for Waste electrical and electronic equipment (WEEE). This means that this product must be handled pursuant to European directive 2012/19/EU in order to be recycled or dismantled to minimize its impact on the environment. User has the choice to give his product to a competent recycling organization or to the retailer when he buys a new electrical or electronic equipment.

Operating Temperature: 0 °C - 40 °C

Operating Humidity: (10% - 90%) RH, non-condensing



Adapter Model: BN049-A05009E

Manufacture: SHENZHEN HEWEISHUN NETWORK TECHNOLOGY CO., LTD.

Input: 100-240V AC, 50/60Hz 0.3A

Output: 9V DC, 0.6A

⎓ : DC Voltage

FAQ

Q1: What should I do if I cannot log in to the web UI of the router by entering 192.168.0.1 or tendawifi.com?

A1: Try the following methods:

- Ensure that the connection between the router and your device is correct.
 - Ensure that your computer is connected to LAN1, LAN2 or LAN3 port properly, and the computer is set to **obtain an IP address automatically**.
 - Ensure that your WiFi-enabled device is connected to the WiFi network of the router.
- Clear the cache of your web browser or replace one.
- Use another computer.
- Reset the router and log in again

Q2: What should I do if I cannot access the internet after configuring internet settings?

A2: Try the following methods:

- Check if the WAN port of the router is connected properly.
- If the LED indicator blinks slowly, login to the web UI of the router, navigate to **Internet Settings**, and follow the on-screen instructions to solve it.
- If your wired devices cannot access the internet:
 - Check whether your computer is connected to LAN1, LAN2 or LAN3 port properly.
 - Check whether your computer is set to **obtain an IP address automatically**.
- If your WiFi-enabled devices cannot access the internet:
 - Check if your WiFi-enabled devices is connected to the WiFi network of the router with the SSID you set;
 - Change your WiFi name and WiFi password. Then try connecting your WiFi-enabled devices again.
- Contact your ISP for help.

Q3: How to change my WiFi name and WiFi password?

A3: Log in to the web UI of the router, and modify them on **Wireless Settings > WiFi Name and Password** page.

Q4: How to reset the router?

A4: Try the following methods:

- When the LED indicator is blinking, hold down the WiFi/RST button for about 8 seconds, then release when the LED indicator blinks fast. The router is reset successfully.
- Log in to the web UI of the router, enter the **Administration page > Device Management** page, click the Reset button and follow the on-screen instructions to reset it.

Copyright

© 2019 Shenzhen Tenda Technology Co., Ltd. All rights reserved. Tenda is a registered trademark legally held by Shenzhen Tenda Technology Co., Ltd. Other brand and product names mentioned herein are trademarks or registered trademarks of their respective holders. Specifications are subject to change without notice.

Technical Support

Shenzhen Tenda Technology Co., Ltd.
6-8 Floor, Tower E3, NO.1001, Zhongshanyuan Road, Nanshan District, Shenzhen, China. 518052

USA hotline: 1-800-570-5892

Toll Free: Daily-9am to 6pm PST

Canada hotline: 1-888-998-8966

Toll Free: Mon - Fri 9 am - 6 pm PST

HongKong Hotline: 00852-81931998

Global Hotline: +86 755-2765 7180 (China Time Zone)

Website: <http://www.tendacn.com>

E-mail: support@tenda.com.cn